

DESIGN PROJECT REPORT

Submitted by

Aryamani

REG. NO: SNG17EE004

In partial fulfilment for the award of the degree

of

BACHELOR OF TECHNOLOGY

in

ELECTRICAL & ELECTRONICS ENGINEERING





SREE NARAYANA GURUKULAM COLLEGE OF ENGINEERING

KADAYIRUPPU, KOLENCHERY 682 311

APJ ABDUL KALAM TECHNOLOGICAL UNIVERSITY

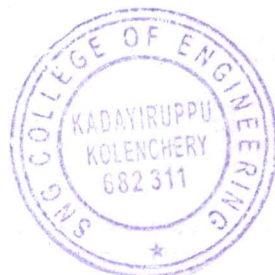
NOVEMBER 2019



PRINCIPAL
Sree Narayana Gurukulam
College of Engineering
Kadayiruppu, Kolenchery-682 311

**SREE NARAYANA GURUKULAM COLLEGE OF ENGINEERING,
KOLENCHERY**



**DEPARTMENT OF ELECTRICAL AND ELECTRONICS
ENGINEERING**

CERTIFICATE

Certified that the design project "VACUUM ERASER FOR BLACKBOARDS" is the bonafide work done by **Aryamani (SNG17EE004)** in partial fulfilment of award of B. Tech Degree in **ELECTRICAL AND ELECTRONICS ENGINEERING**.

Guide

Ms. Arya Prakash

Assistant Professor

Department of EEE

HOD EEE

Ms. Reshmila S

Associate Professor

Department of EEE

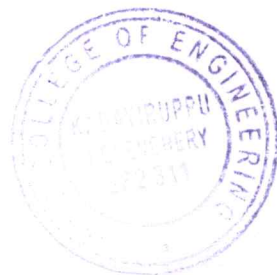

PRINCIPAL

**Sree Narayana Gurukulam
College of Engineering
Kadayiruppu, Kolenchery-682 311**

ERASER SECTION

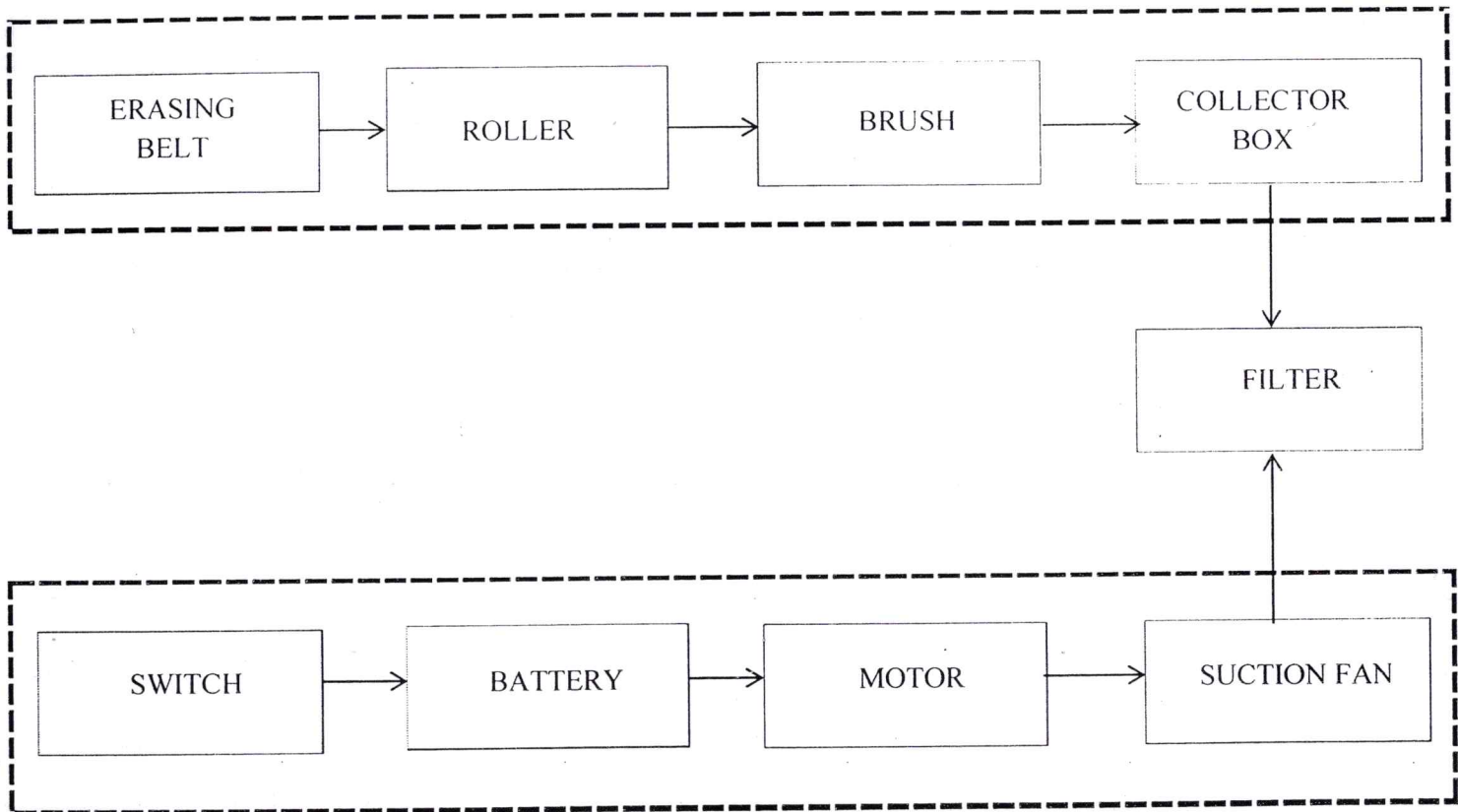

SUCTION SECTION



Fig 5.1: Block Diagram of vacuum eraser

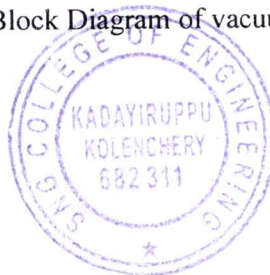

A. Alex
PRINCIPAL
Sree Narayana Gurukutam
College of Engineering
Kadayiruppu, Kolenchery-682 311

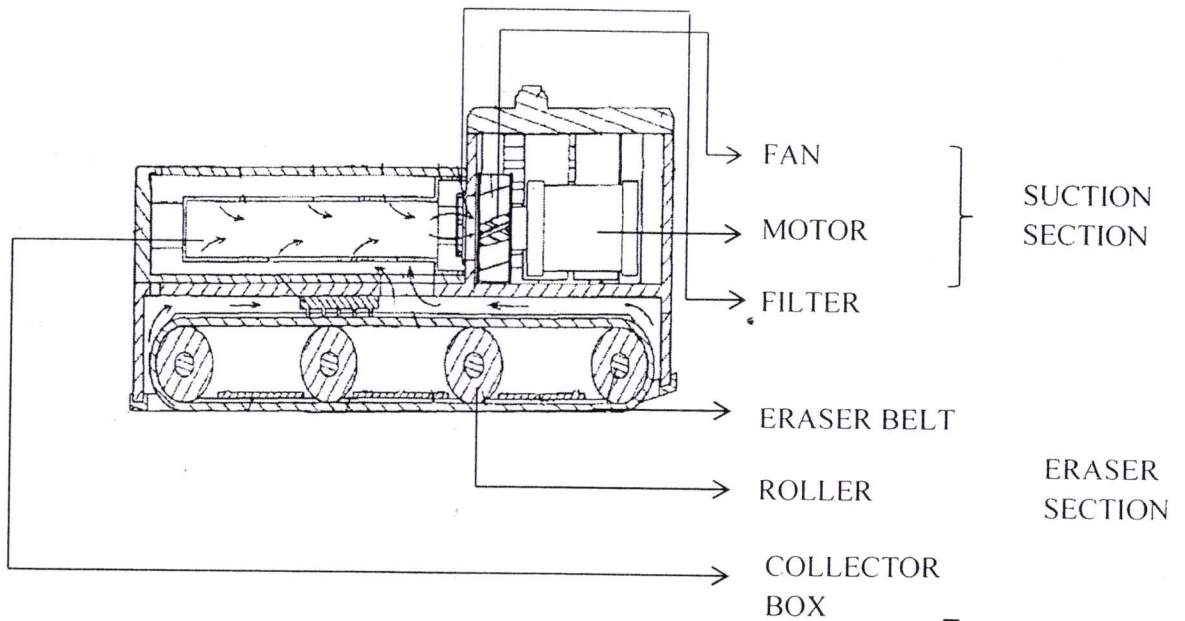

Fig 5.9: Cross sectional view of vacuum eraser

1. ERASER SECTION:

The eraser can be moved through the black board using the rollers. Rollers along with the eraser belt act as a conveyer system. When the rollers are moved back and forth, the eraser belt comes in contact with the brushes which are located below the collector box which in turn removes the dust from the belt.

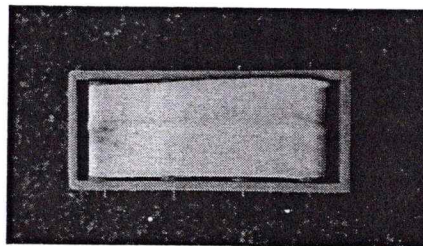
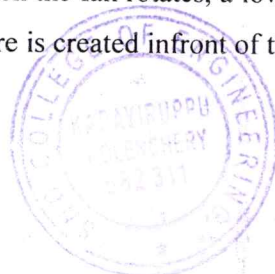

Fig 5.10: Eraser Section

2. SUCTION SECTION:

The switch enables the ON and OFF operations. When the switch is ON, the battery supplies power to the motor. Motor is attached to a suction fan. When the fan rotates, a low pressure is created behind the fan and high pressure is created in front of the fan. Due to this pressure



Sree Narayana Gurukulam
College of Engineering 24g
Kadayiruppu, Kolenchery-682 311

difference, air along with the dust particles is sucked into the collector box through an inlet. A filter is provided near to the suction fan so that no dust particles enter the motor compartment.

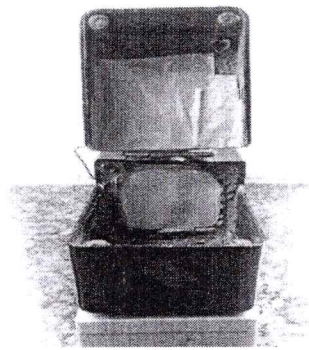

Fig5.11: Collector Section

5.4 RESULT

The proposed design was successfully completed using vacuum technology. Unlike the normal blackboard erasers, vacuum eraser prevents the circulation of chalk dust inside the classroom and thus provides a healthy environment.

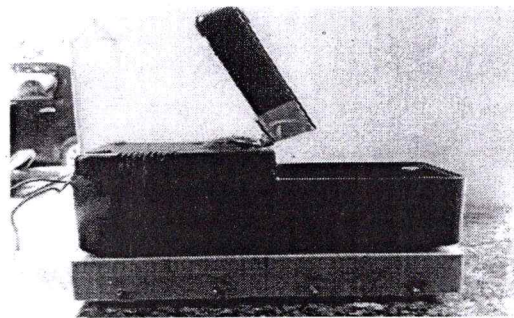
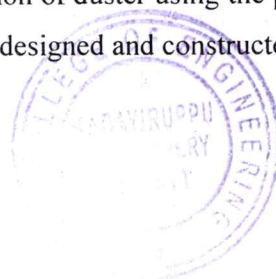

Fig 5.12: Vacuum eraser

5.5 CONCLUSION

An improved version of duster using the principle of vacuum that can be used in schools and colleges is designed and constructed. The chalk dust creates many



A. Arav
PRINCIPAL
Sree Narayana Gurukulam
College of Engineering
Kadayiruppu, Kotenchery-682 311

SELF STABILIZING SPOON

MAIN PROJECT REPORT

Submitted by

ALAN BABU (SNG17EC005)
JIBIN BABU (SNG16EC020)
KRISHNENDU K M (SNG17EC017)

To

The APJ Abdul Kalam Technological University

In partial fulfilment of the requirements for the award of the Degree of

Bachelor of Technology In

Electronics and Communication Engineering



Department of Electronics and Communication Engineering

Sree Narayana Gurukulam College of Engineering

Kadayiruppu May 2021





PRINCIPAL
Sree Narayana Gurukulam
College of Engineering
Kadayiruppu, Kolenchery
Kerala - 682311

ABSTRACT

The technology for assisting people who are functionally challenged has improved over the recent decades. Parkinson's disease is a brain disorder that leads to shaking, stiffness, and difficulty with walking, balance, and coordination. Parkinson's symptoms usually begin gradually and get worse over time. As the disease progresses, people may have difficulty walking and talking. With today's technology, people with Parkinson's disease can, with a device on their wrist, are able to draw pictures, eat food.

The purpose of this thesis is to analyze how a microcontroller can be utilized to help people with impaired motor skills during their eating process. A stabilizing spoon is a device which maintains a horizontal position of its front regardless of the motion it receives from the user at the rear end of the spoon. Its aim is to assist these people so they can eat independently.

In our project we have designed a stabilizing handle controlled by a servo motor to counter the tremors. The motion is detected from an inertial measurement unit (IMU) MPU6050 housed on the handle. A closed-loop control of the handle position is then implemented to actuate the handle to keep it close to a desired angle relative to the ground. The user can also interact with the system to set the desired angle through a force sensing resistor (FSR). Weight of the system is extremely small by using light materials and sparse structures. The cost of the system is also much less. A vibration generator is designed specifically to test the performance of the prototype quantitatively. A prototype of a stabilizing spoon was constructed in the FAB LAB to work under real circumstances and intended to be a complement for people who are in need of assistance during their eating process.

PRINCIPAL
Brahma Narayana Gurukulam
College of Engineering
Kadavur, Tamil Nadu 622 311

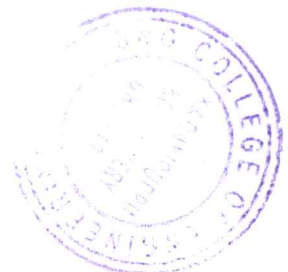

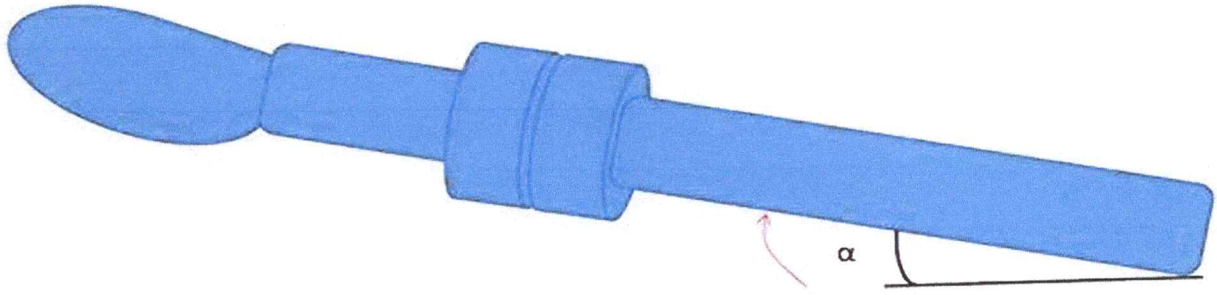

a)

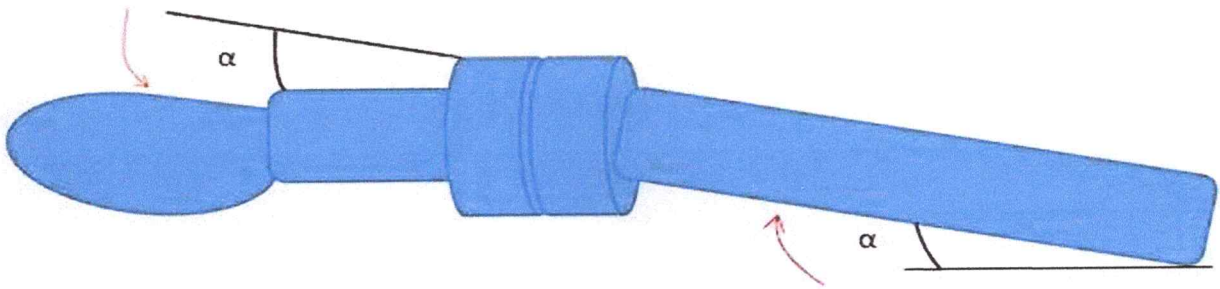

b)

A. Ar

PRINCIPAL
Sree Narayana Gurukulam
College of Engineering
Kadayiruppu, Kollam - 686 012



MULTIPURPOSE INTELLIGENT CANISTER

PROJECT REPORT

submitted by

ARUN P. MADHU (SNG18EC003)

ELIAS M SHAJI (SNG18EC006)

to

the APJ Abdul Kalam Technological University

in partial fulfilment of the requirements for the award of the Degree

of

Bachelor of Technology in

Electronics and Communication Engineering



Department of Electronics and Communication Engineering

Sree Narayana Gurukulam College of Engineering Kadayiruppu

June 2022

PRINCIPAL
Sree Narayana Gurukulam
College of Engineering
Kadayiruppu, Kolenchery-682 311



ABSTRACT

In today's world, when the cost of living goes up, both parents have to work to make ends meet. This busy work-life schedule makes people forget small day-to-day stuff. For example, people forget about buying groceries and grains and such. Let's imagine if someone forgot to buy chili powder and they gave none at home. It may prove to be a problem that could have been easily avoided. In such a situation, Multipurpose Intelligent Canister can make your life easier. Multipurpose Intelligent Canister is a special type of smart container which is the technologically advanced version of today's container that can be used in the kitchen, hospitals, laboratories, etc. These canisters are capable of tracking the expiry and the exact amount of commodity inside it and alert the user when it gets expired or depleted below a certain level via a smartphone using IoT. It can recognize voice commands from the user and can perform different functions such as dispensing an exact amount of commodity as instructed by the user. Standing out itself from a group of containers when its name is called by using a LED indicator. For example, if we say 'chili powder' the container having chili powder glow up the LED indicator. The LED indicator in the canister gives visual indications of different functions according to the voice commands. It can be wirelessly charged from its dock. We have designed a 3-D model in the FAB LAB keeping in mind the ergonomic and utility concerns. The canister is an IoT-based model which can easily connect to your smartphone.

The entire system was designed keeping in mind the futuristic look as well as the ergonomic aspects. The figures below illustrate 2D as well as 3D conceptual models of the proposed canister.



PRINCIPAL
Sree Narayana Gurukulam
College of Engineering
Kadaviruppu, Kolenchery-682311

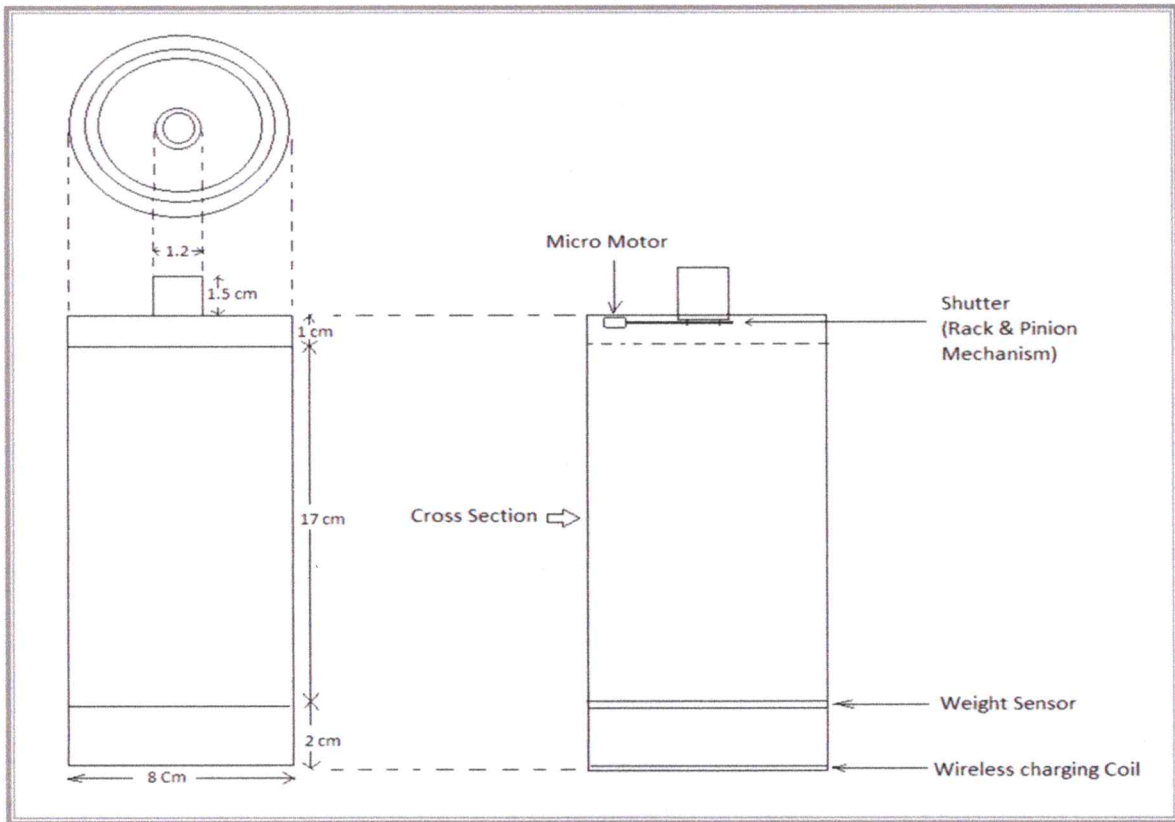

2D Design of the canister

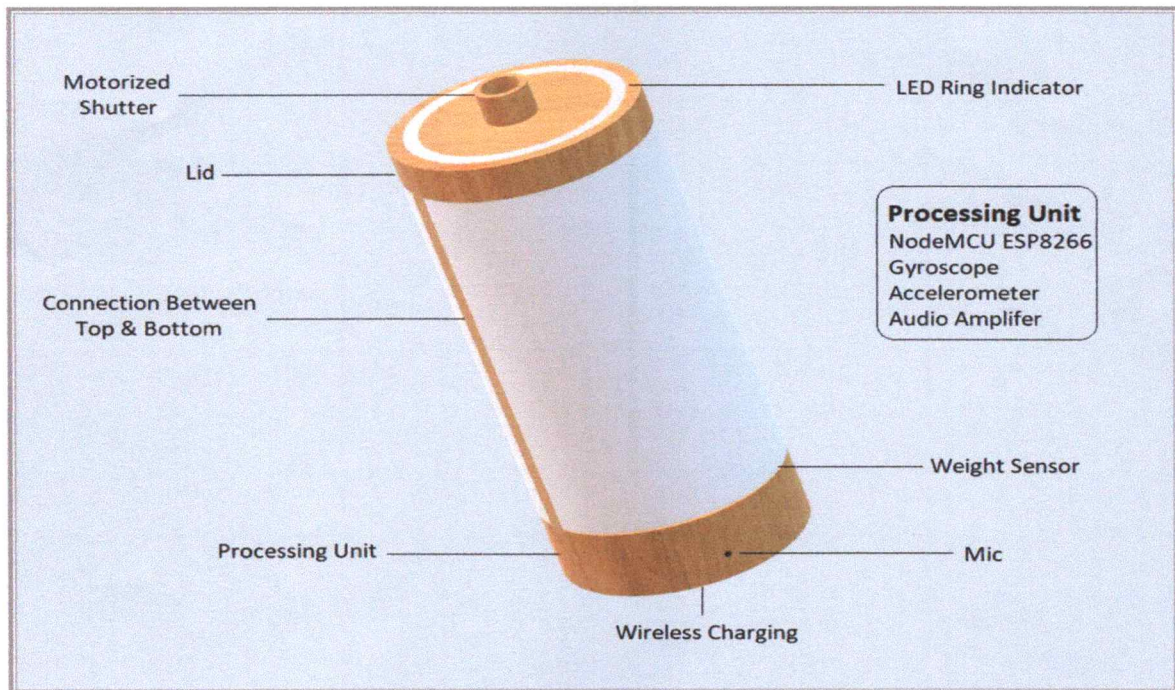

3D Design of the canister



PRINCIPAL
Sree Narayana Gurukutam
College of Engineering
Kadayiruppu, Kolenchery-682



Prototype



A. Huse
PRINCIPAL
Sree Narayana Gurukulam
College of Engineering
Kadayiruppu, Kolenchery-682



Top view of the canister

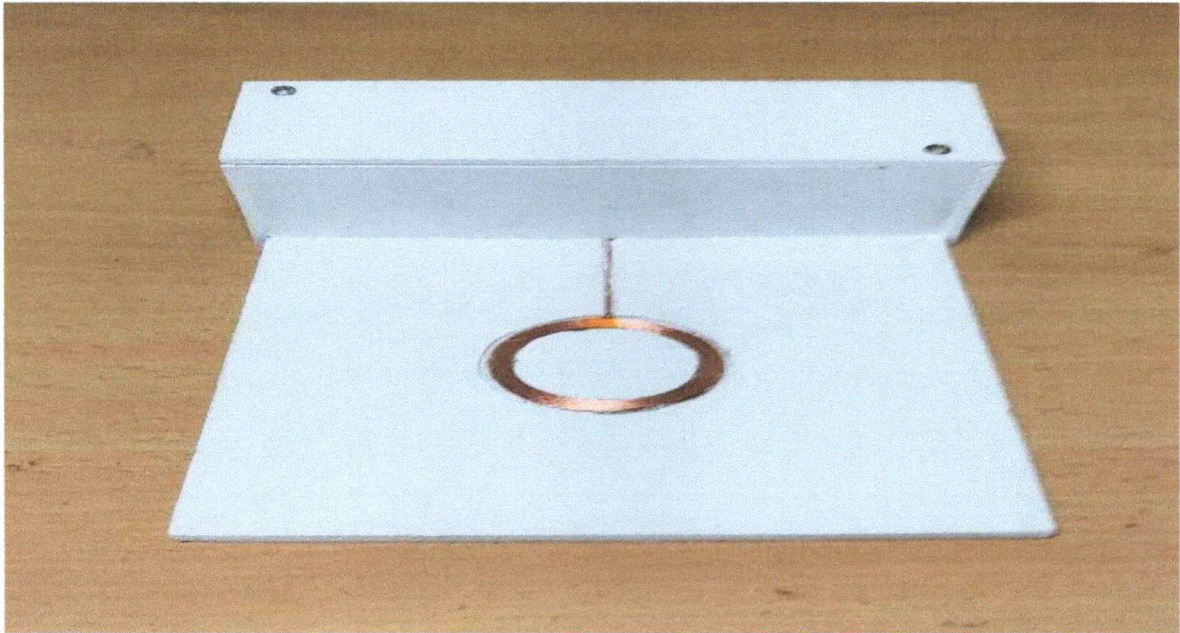

A. H. M.
Charging dock



PRINCIPAL
Sree Narayana Gurukulam
College of Engineering
Kadayiruppu, Kolenchery-682 311